

THANK-YOU FOR CHOOSING KOHLER COMPANY

We appreciate your commitment to Kohler quality. Please take a few minutes to review this manual before you start installation. If you encounter any installation or performance problems, please don't hesitate to contact us. Our phone numbers are listed on the final page. Thanks again for choosing Kohler Company.

BEFORE YOU BEGIN

- Read the installation guide carefully and install the product accordingly.
- The product information contained in this publication is correct at the time of printing. Kohler Co. reserves the right to implement changes to this guide, product characteristics, packaging and availability at any time without further notice.
- Do not use corrosive cleaners or solvents in or on the tank. This may damage the tank. Mild detergent can be used.
- Do not use any spare parts which are not supplied by Kohler. Kohler will not be responsible for any damage due to the installation of non approved spare parts.
- Observe all local plumbing and building codes. Installation shall be in accordance with AS/NZS 3500 and AS/NZS 6400.

WARNING

- This product is designed for a water supply pressure range of 20 psi (137kPa) minimum to 72.5psi (500 kPa) maximum.
- Any installations where the supply pressure is outside of these limits will not be covered by warranty.

ORDERING INFORMATION

HYDRO-TOWER 200 PNE IWT W/O FRAME 3/4.5L78074A-PNE-NA
 PEBBLE Pneumatic In-Wall Tank Faceplate (For Separate Purchase).....20341T-PNE-CP

SPECIFICATIONS

Liters per flush	78074A-PNE-NA	Full flush volume: 4.5L Half flush volume: 3L
Operating temperature range	Environmental temperature: 1°C to 55°C Water temperature: 1°C to 45°C	

RECOMMENDED TOOLS AND MATERIALS

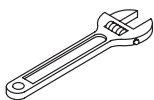

10" Adjustable Wrench



Supply Shut-off Valve

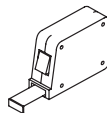

Tape Measure

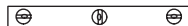

Level



Sponge

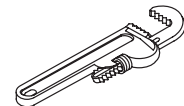

Pipe wrench

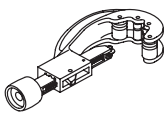

Tubing Cutter

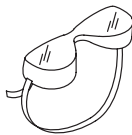

Safety Glasses

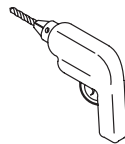

Drill and assorted bits

Plus:

- Connector
- Metal File
- 1/2" Nut Driver/Socket
- Saw
- Screwdriver
- M8 Coach/TEK Screws x 4
- Appropriate fasteners for masonry or timber construction.

ROUGH-IN

78074A-PNE-NA installed with 20341T-PNE-CP

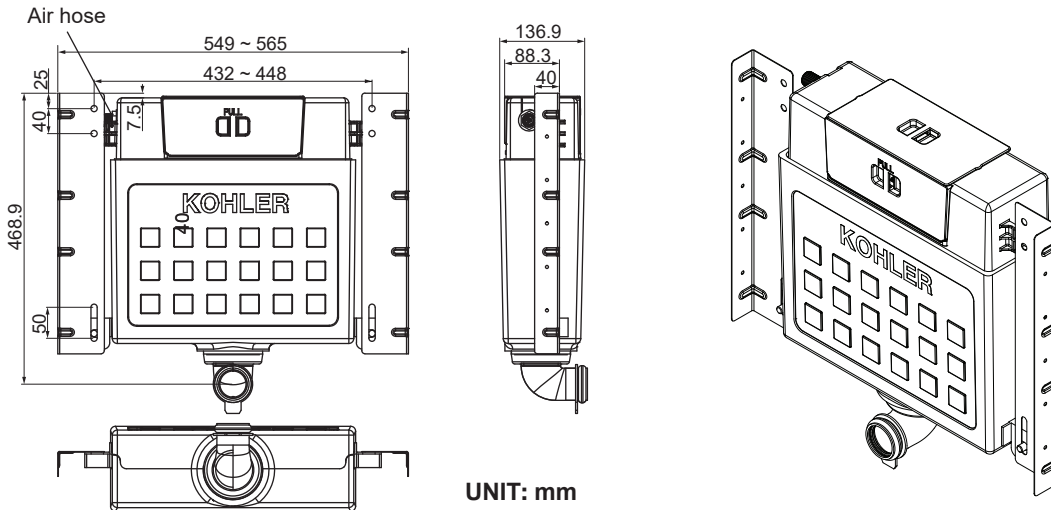

A1) INSTALLATION FOR IN-WALL TANK WITHOUT FRAME

The In-wall tank without frame (78074A-PNE-NA) should be used with wall faced toilets.

Note: Minimum cavity (stud pocket) dimensions for installation of the in-wall tank, 555 mm wide, 150mm deep.



In-Wall Tank Without Frame on concrete

In-Wall Tank Without Frame on timber

1. Remove the front cover or top cover from the tank as shown.
2. Remove the support block from inside of the tank.
3. Remove the plug.

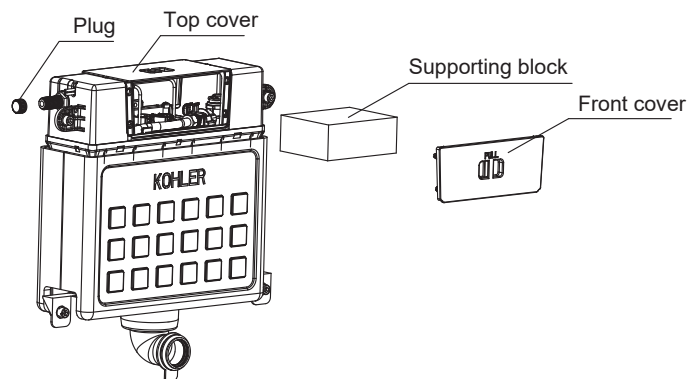

To install on concrete:

1. Place the frame into the cavity.
2. For the distance from the finished floor level to the centre of the water inlet, please refer to the pan installation instruction.
3. Drill 4 holes with the diameter of $\varnothing 10$ and 80mm depth.
4. Insert the flush head sleeve masonry anchor and tighten the anchor bolts with the nut by spanner.

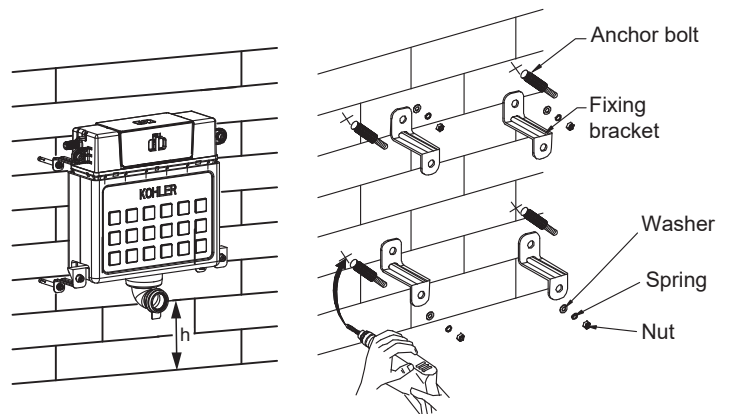

5. Place tank onto the fixing bracket as shown in the picture.

NOTE: Ensure the tank is level.

6. Tighten screws with allen key.

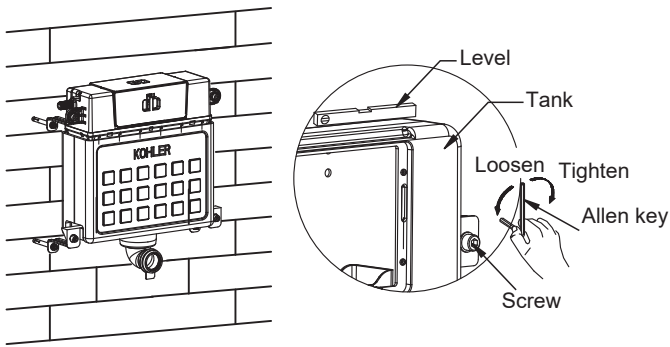

To install on timber:

1. Mount the brackets on tank as shown in picture and tighten the screws by nuts using allen key and spanner.

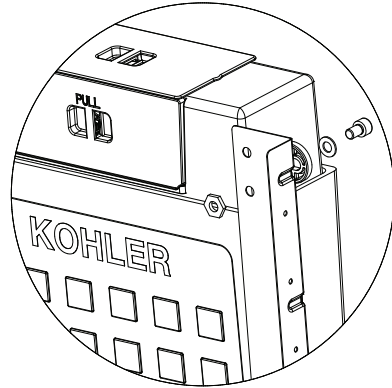

2. Fit the in wall tank to the stud's using the tek screws ensuring the centre of the water inlet is at the correct distance above the finished floor level.

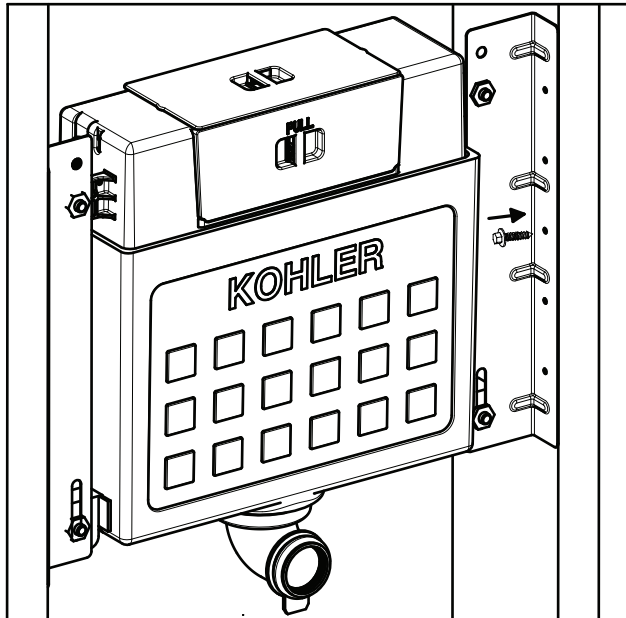

Connecting the air hose

- Ensure the water tank internal shut off valve is OFF. Note: Turn anti-clockwise to close and clockwise to open.
- Connect the water inlet hose (not supplied) to the tank water inlet.

- **Fit the flush pipe cover.**

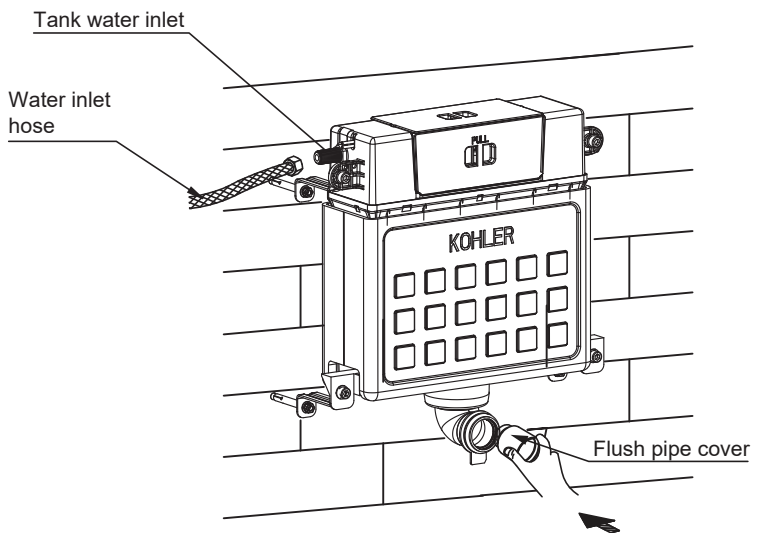

A2) FACE PLATE/ACCESS PANEL INSTALLATION METHODS

There are four ways to install access panel:

Method one: Press from top

Method two: Remote locking plate installation

Method three: Remote installation of flush button shield

Method four: Press from front: fix four pinch plates with screws

Important: For methods two and three, remote access panel installation a removable panel must be installed either to the top or front of the cistern access to the cistern parts/valves for maintenance purposes. Fix the cover onto the tank and pull the air hose to the faceplate.

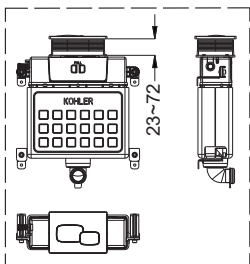

Method one

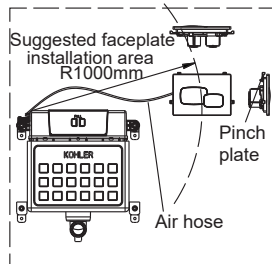

Method two

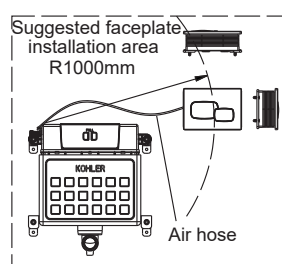

Method three

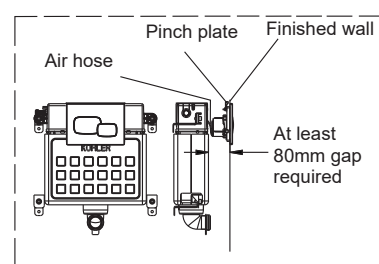

Method four

A2-1 :Press from top

1. Remove the top cover, then install the rectangular shield on the top of the tank, and tighten the screw to fix the shield.
2. Cut the cable tie of the air hose and pull it out from the shield.

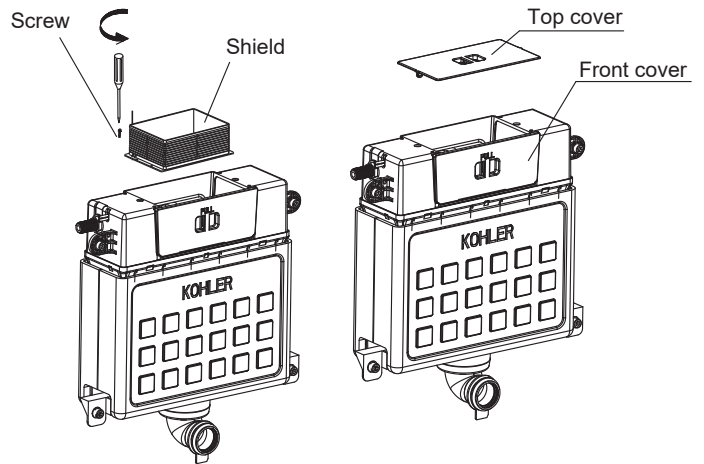
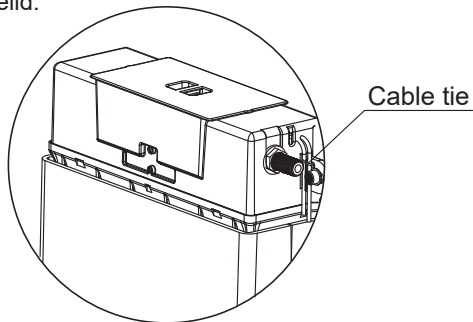

Prepare and finish the wall

IMPORTANT:

- a. When preparing the wall, the wallboard/tiling cut-out must fit very neatly around the square cover of flush panel. No large gaps are permitted (tolerance of approx 1mm).
- b. There may be significant amounts of dust when preparing the wall - ensure to fit dust cover over cistern opening and protect the electrical fittings and pipework.
- c. We recommend before cutting the gib board the toilet is fitted to the wall to verify the waste pipe for P-trap and flush pipe height is correct to the finished floor level. Cut the gib board to suit the position of the flush plate, waste pipe, flush pipe and toilet fixing holes. Fit the gib board to the stud.

3. Remove the waste pipe and flush pipe cover.
4. Using a sharp knife trim the flush plate shield back level with the finished wall. If the finished wall is to be tiled please ensure the thickness of the tile is included. The trimmed flush plate shield must sit flush with the finished wall.

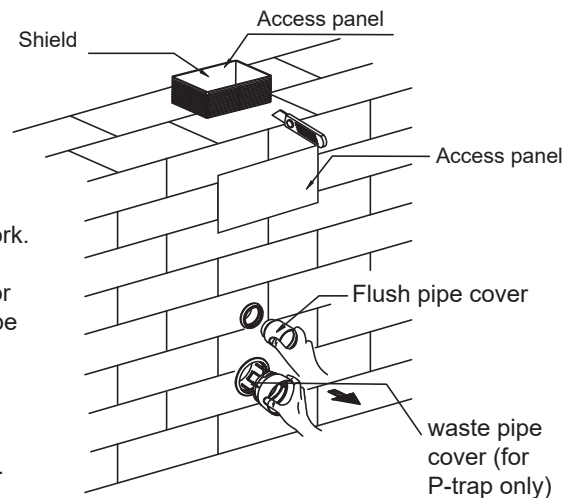

5. Fix the locking plate to the flush plate shield using the plastic locking bolts. When locating the four locking bolts on supporting board, turn the locking bolts clockwise to the OPEN mark.

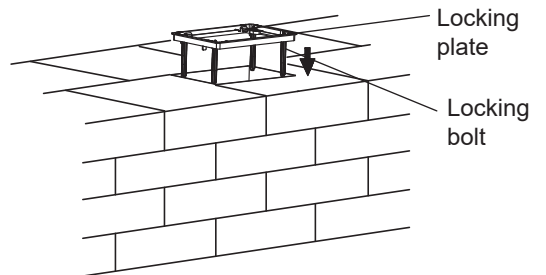

6. To lock the bolts in position turn the bolt counter-clockwise until the tab on the bolt head is vertical to LOCK mark.

Note: Do not use excessive force - hand tighten only.

7. Trim the length of the locking bolts if required.

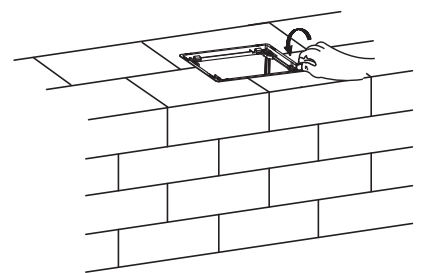
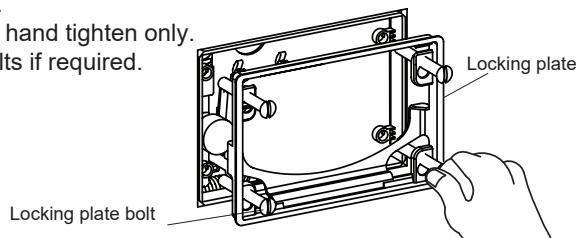

8. Fit the red full flush air hose and the blue reduced flush air hose to the faceplate.
9. Push the faceplate into the locking plate until it locks into place.

Note: Cut the excessive parts of the air hose if necessary and fix it onto the tank fastener.

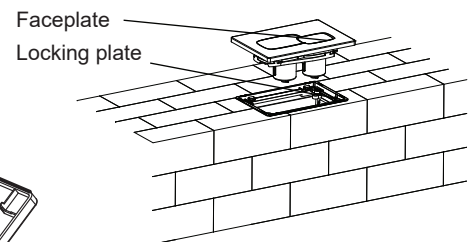
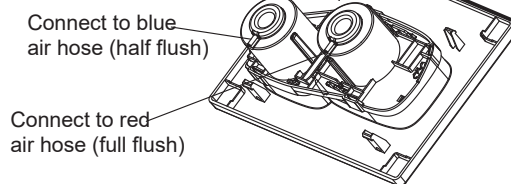
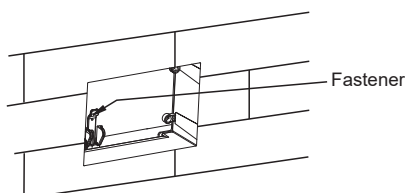

10. The cistern should now be ready to use.

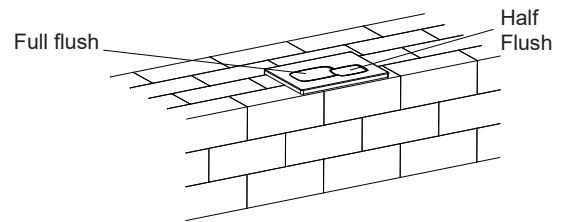

A2-2 :Remote locking plate installation

- 7~20mm thickness is recommended for the finished wall and at least 80mm gap for faceplate.
- Use four screws to fix locking plate by four pinch plates to the wall.
- Follow the steps 8-10 of A2-1 to complete the faceplate installation.

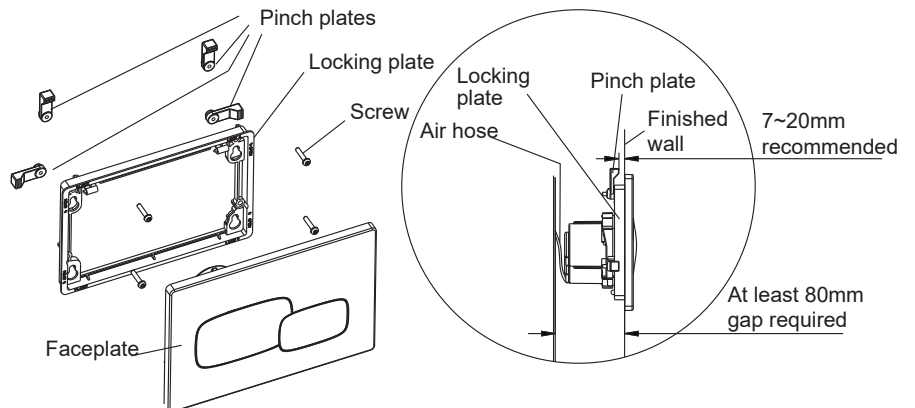

A2-3 :Remote installation of flush button shield

- Add a nog to studs where you want to install the faceplate to mount the shield on.
- Drill 4 holes with diameter of 10mm and depth of 16mm are needed to locate the locking plate bolts.
- Drill 10mm hole for air hose on the side of shield.
- Mount the shield on nog using self-tapping screws.
- Do not cut the shield as the full length of shield is needed to accommodate the minimum space that is required for faceplate.
- Follow the steps 5-10 of A2-1 to complete the faceplate installation.

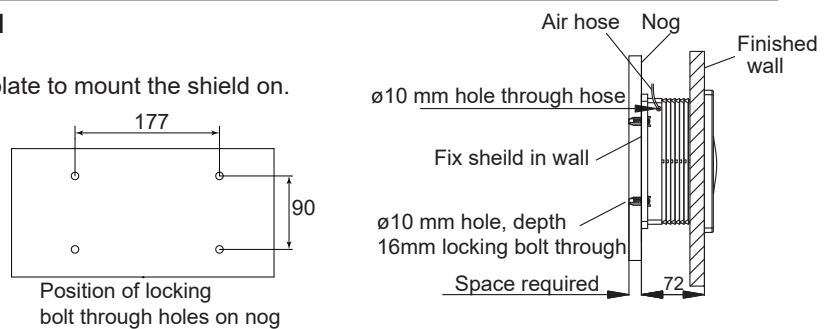

A2-4 :Press from front: fix four plates with screws

- Cut the cable tie of the air hose and pull it out from the tank
- Ensure the tank is accessible through front or top for future maintenance.
- Fix the four plates with screws and then fix the locking plate.
- No direct contact between the faceplate and the tank as the 80mm gap is required to support the faceplate thickness.
- 7~20mm thickness recommended for the finished wall.
- Follow the steps 8-10 of A2-1 to complete the faceplate installation.

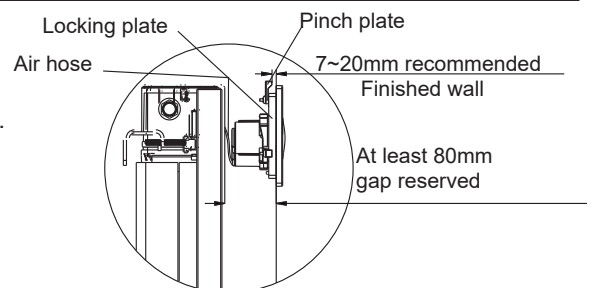

A4) INSTALLATION OF TOILET

1. Fit the flush pipe connector to the flush pipe inlet on the toilet.
2. Fit the waste pipe connector to the waste pipe outlet on the toilet.
3. Mark on the pipe connectors the position of the rear of the toilet.
4. Remove the pipe connectors.
5. Mark on the pipe connectors a second line, which represents the connection distance required to connect the toilet to the flush and waste pipes within the wall. This connection distance is the distance between the rear of the tank and the hole in the gib board.

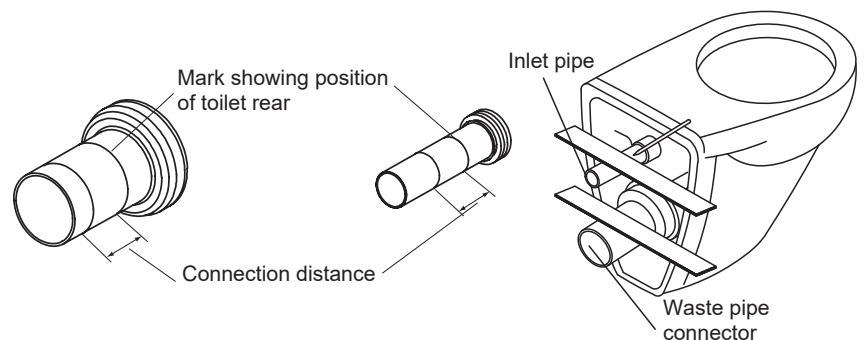

6. Cut both the waste pipe and flush pipe at the connection distance marks.
7. Remove all burrs from the cut edges and reinstall on the toilet.

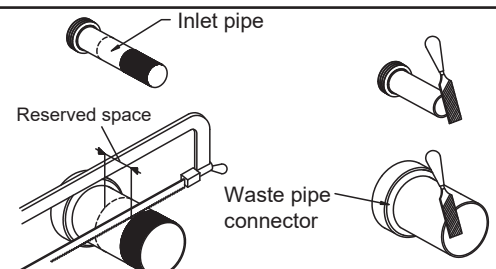

8. Fit the flush pipe connector and seal to the flush pipe inlet on the toilet.
9. Fit the waste pipe connector and seal to the waste pipe outlet on the toilet

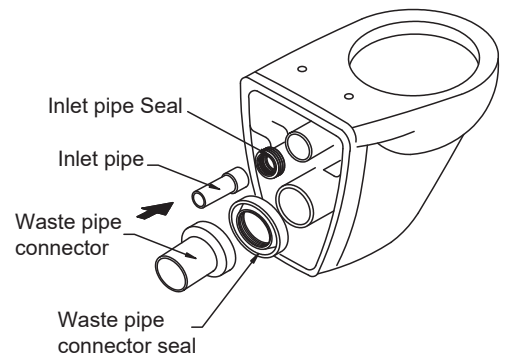

10. Place the toilet back to wall and fix it to floor using pan fixing kit. For bowl installation please refer to pan installation instruction.
11. Ensure the toilet is level.

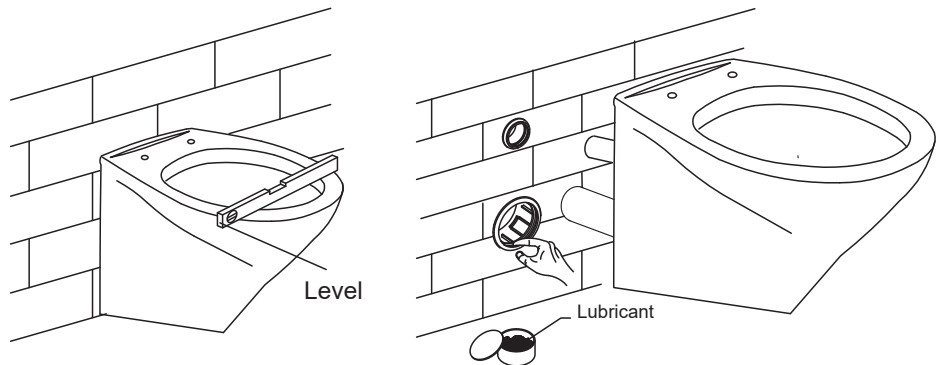

B) REMOVAL AND MAINTENANCE OF CISTERN COMPONENTS

1. First unlock the faceplate from the mounting frame.
2. Remove the full flush air hose and reduced flush air hose. Then remove the faceplate.

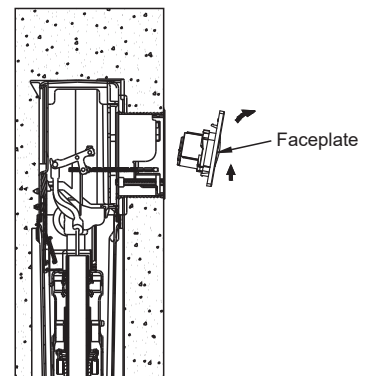
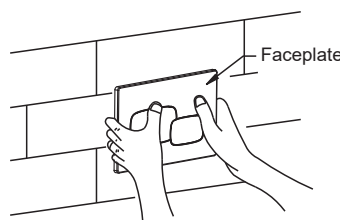
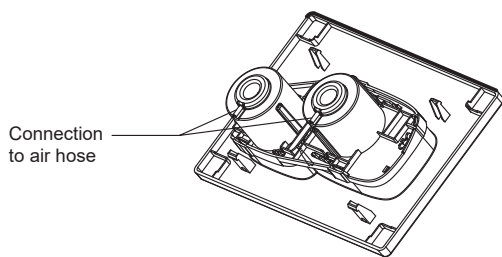

3. Carefully loosen the four locking screws by rotating them clockwise until the screw slots align with open tabs.
Warning: No tools or excessive force should be used to rotate the locking screws to the "OPEN" position.

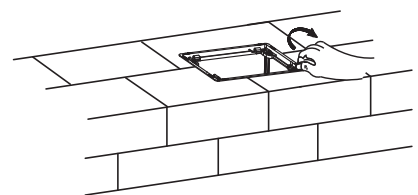

4. Disassemble faceplate supporting frame as shown.

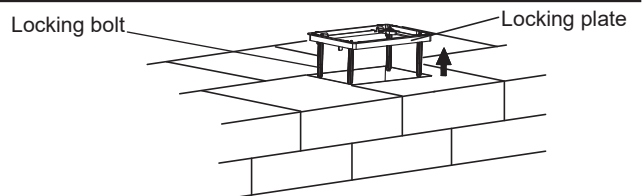

5. Rotate the shut off valve actuator handle clockwise to open and anti-clockwise to close.

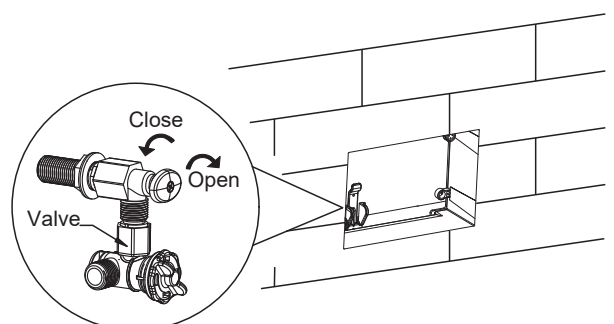

6. Unscrew the hose from the inlet valve. Press the release clip and lift to remove the inlet valve.

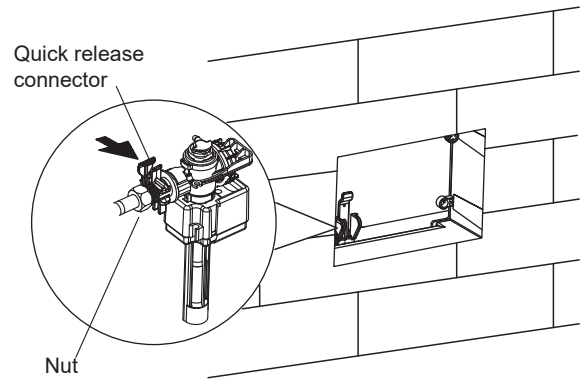

7. Push the clip of the toilet detergent box and lift to remove from cistern.

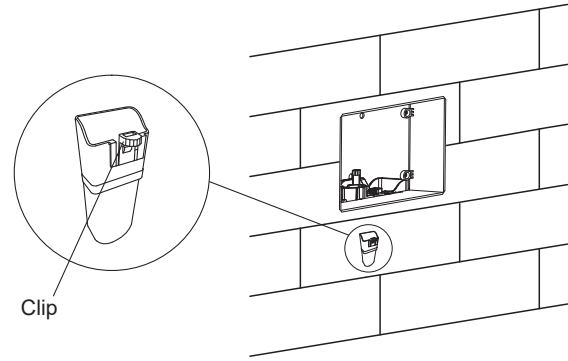

8. Disconnect the outlet valve actuator arms for the full and reduced flush by pushing towards the centre of the cistern while applying pressure to both top and bottom of the pivot. Remove the pneumatic actuator assembly by lifting the rear of the frame to release the snap clips. Hold the pneumatic hose ends and pull up to remove.

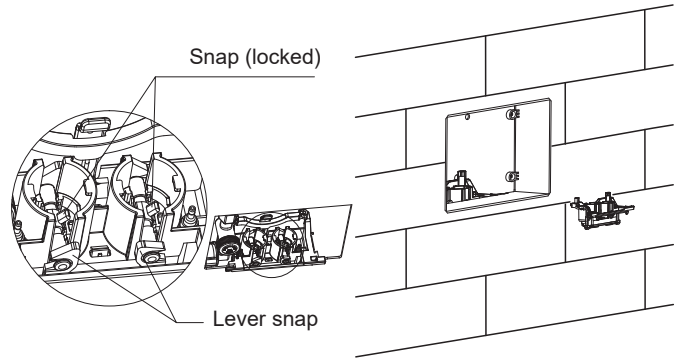

9. To remove the flush valve Security tab at the rear of the cistern, pull forward on the tab and lift out.

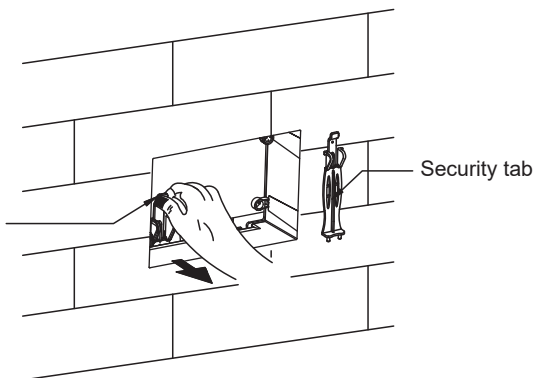

10. With the flush valve fastener removed, the flush valve can be lifted out.

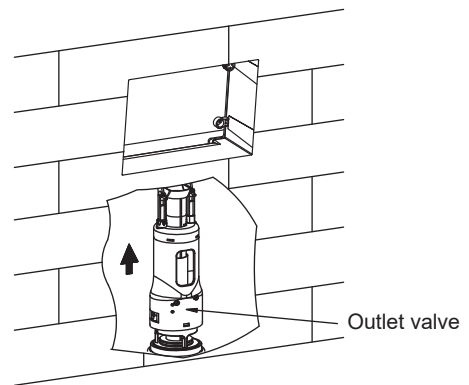

11. Remove discharge valve for cleaning or adjusting.

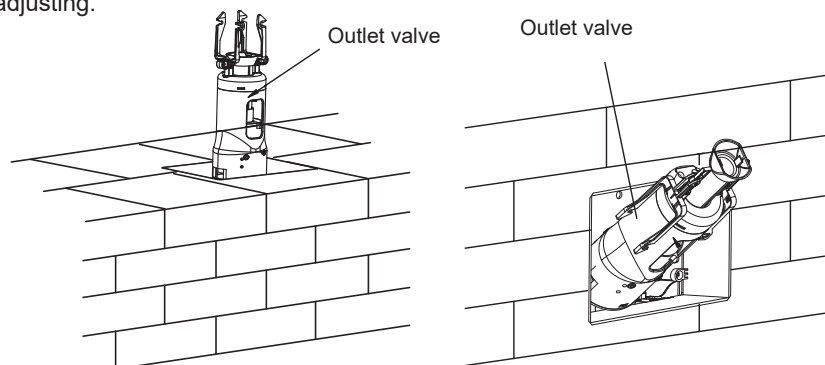

Cleaning the mesh filter

● To clean the mesh filter, release by rotating counter clockwise then pull free. Rinse clean and fit before replacing the flush vavle.

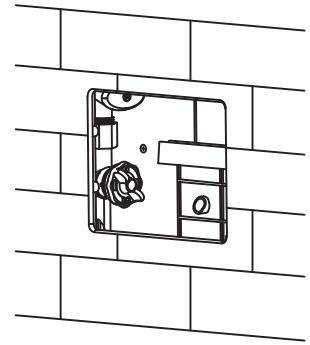
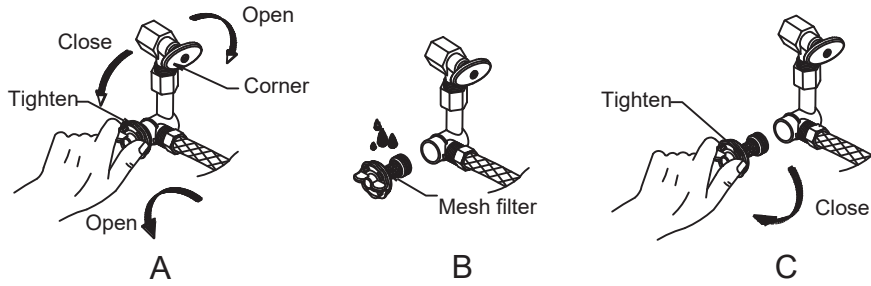

Adjusting Inlet Valve

● Raise or lower the water level in the tank by adjusting the float level with the adjusting screw. Turn clockwise to increase the water level and counter clockwise to reduce. The water level must align with the water line mark in the tank.

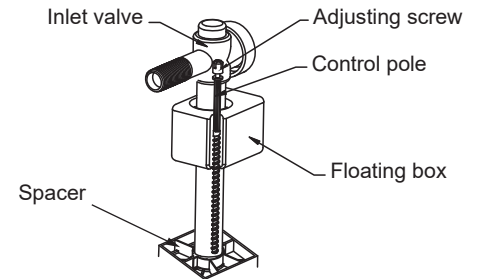

Adjusting Outlet Valve

● If the flush volume is incorrect, the flush volume and overflow level of the tank can be altered by adjusting the valve:
 For full flush, adjust the bottom slide adjustment switch. Adjust up to increase volume.
 For reduced flush adjustment, adjust the float level. Adjust up to increase volume. The reduced flush water lower level will be at the bottom of the float.

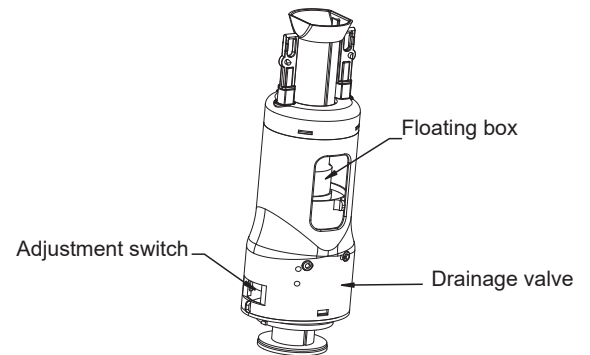

TROUBLE SHOOTING PROCEDURES

Symptoms	Probable Causes	Recommended Action
No water fills in via inlet valve	The inlet valve is closed.	Open inlet valve.
	Floating box of inlet valve is blocked by other parts.	Readjust the position of other parts to avoid contacting the floating box when it is functioning.
	Floating box of inlet valve is block by waste.	Wash the floating box with clean water.
Not flushing	The air hose and faceplate are wrongly installed.	Reinstall the air hose.
	The actuator and flush vavle not connected.	Reinstall the fastener bracket onto the body of the outlet valve.
Too high or too low water volume	The floating box of the inlet valve is not properly adjusted.	Readjust the water level to align with the waterline mark.
Water leaking into toilet pan	The floating box of the inlet valve is blocked by waste, so the water is leaking from the overflow pipe.	Readjust the position of other parts to avoid contacting the floating box when it is functioning.
	The flush valve seal is blocked by waste or damaged.	Take out the outlet valve, clean, or replace the rubber seal.
Toilet does not flush	A. No water supply. B. The shut off valve is closed.	A. Wait for restoration of water supply. B. Open the water supply stop.
Toilet does not flush properly.	Filter screen is clogged.	Clean the water mesh filter.

CONTACT & WARRANTY INFORMATION

For warranty information, please visit our website

New Zealand
www.kohler.co.nz

Australia
www.kohler.com.au

KOHLER[®]

CALL US FOR HELP

NEW ZEALAND
KOHLER NZ LTD

Free Ph: 0800 564 537 (0800 KOHLER)
Free Fax: 0800 664 488
www.kohler.co.nz

AUSTRALIA
KOHLER CO.

Free Ph: 1 800 KOHLER
(1 800 564 537)
www.kohler.com.au