

# SAPPHIRE™ RECTANGULAR SPA BATH (2 PERSON)



**Features/Options:** -Upstand: 12.5mm upstand for watertightness

**Material/Finishes:** -Chrome jets  
-Chrome suction cover

**Controls** -Electronic switch. Manual airflow control  
**Pump** -Hot  
**Number of Jets** -14 adjustable jet: 8 back jets and 6 body jets

**Included Components:** -Timber Frame  
-Bodyguard® safety valve

Size	External Dimensions (mm)			Internal Dimensions (mm)			Volume (L)
	Length	Width	Depth	Max Bathing Depth	Seating Base Width	Base Length	Full Capacity
1800 x 900mm	1800	900	540 min	520	480	1240	385

Product	Chrome jets
1800 x 900mm Pump Access A	45812A-ABCP5-0
1800 x 900mm Pump Access B	45812A-DEFP5-0

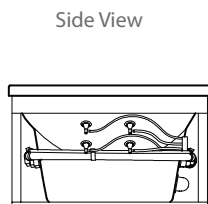
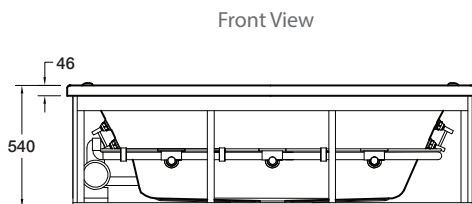
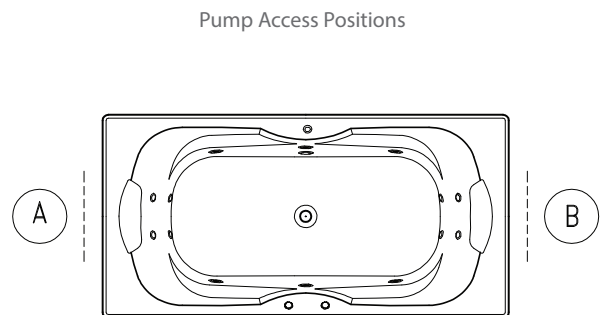
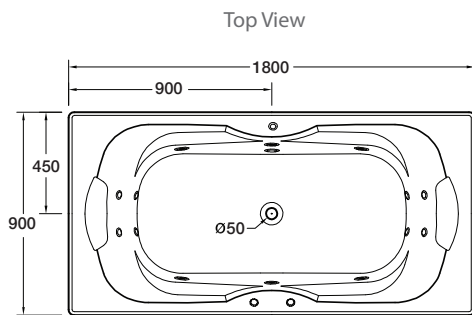

**New Zealand**  
133 Diana Drive, Glenfield, Auckland, NZ  
PO Box 100-146 NSMC, Auckland, 0745  
Ph: 0800 100 382 Fax: 0800 66 44 88  
www.Englefield.co.nz

**Australia**  
PO Box 253, Alexandria, NSW 1435  
Ph: 1800 ENGLEFIELD (1800 364 533)  
www.Englefield.com

All measurements shown are in millimetres.  
Sizes are approximate.

December 2023  
1201142 -A04-D