

INSTALLATION INSTRUCTIONS



TAPWARE | SORRENTO™ BASIN MIXER - LEAD FREE 35342A

BEFORE YOU BEGIN:

All information is based on the latest product information at the time of publication. Englefield reserves the right to make changes in product characteristics, packaging, or availability at any time without notice. Please leave this installation instruction for the consumer as it contains important information.

Scope of Use:

1. Flush the water supply pipes thoroughly to remove debris before installation.
2. An in-line water filter must be used with this product.
3. This mixer is intended for equal hot & cold water pressures.
4. This mixer is not suitable for use in uncontrolled heating systems such as a wet-back or solar heating system, unless a proper tempering valve is installed.
5. Operating pressure: Min. 35kPa, Max. 500kPa. If supply exceeds 500kPa a pressure limiting valve must be installed.
6. Operating temperature: Cold: 5°C to 20°C, Hot: 50°C to 65°C.
7. All connections must be checked for leaks after installation.
8. Ensure all local plumbing codes are observed.
9. All installations should comply with the relevant requirements of AS/NZS3500 & AS/NZS6400.
10. All installations should comply with the lead free requirements of the National Construction Code Volume three.
11. **DO NOT** hydrostatic test the water supply pipe installation with this mixer installed. Damage to the ceramic cartridge may occur.
12. Use only water to pressure test this product. Before the test, ensure to flush any air from the mixer & pipework thoroughly. Max. test pressure 800kPa and Max. test duration 30 minutes.

ROUGH-IN:

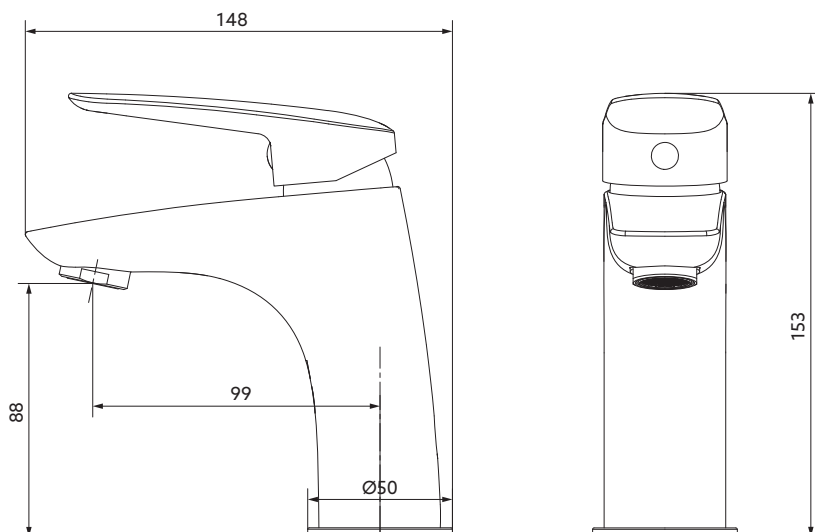

All dimensions in millimetres

MIXER INSTALLATION:

1. Connect the inlet hoses (8) to the mixer body (1).
2. Screw the threaded studs (6) into the mixer body and then place the O-ring (3) into groove under the base (2).
3. Feed the hoses through the basin hole and position the mixer in place on the basin.
NOTE: basin hole maximum diameter Ø35mm.
4. From the underside of the basin, place the rubber washer (4) on top of the mounting plate (5) and feed them over the threaded studs.
5. Fit the nuts (7) onto the threaded studs and tighten to secure the mixer.
6. Ensure that all connections are tight. Ensure that the handle is in OFF position.
7. Open the basin drain as necessary. Turn on main water supply and check for leaks.
8. Remove flow aerator (10) & rubber washer (9) by unscrewing the shell (11). Turn on the mixer. Run hot & cold water through spout to remove any debris. Turn off the mixer.
9. Reinstall the flow aerator & rubber washer back and tighten it properly to prevent removal of the flow aerator by hand.

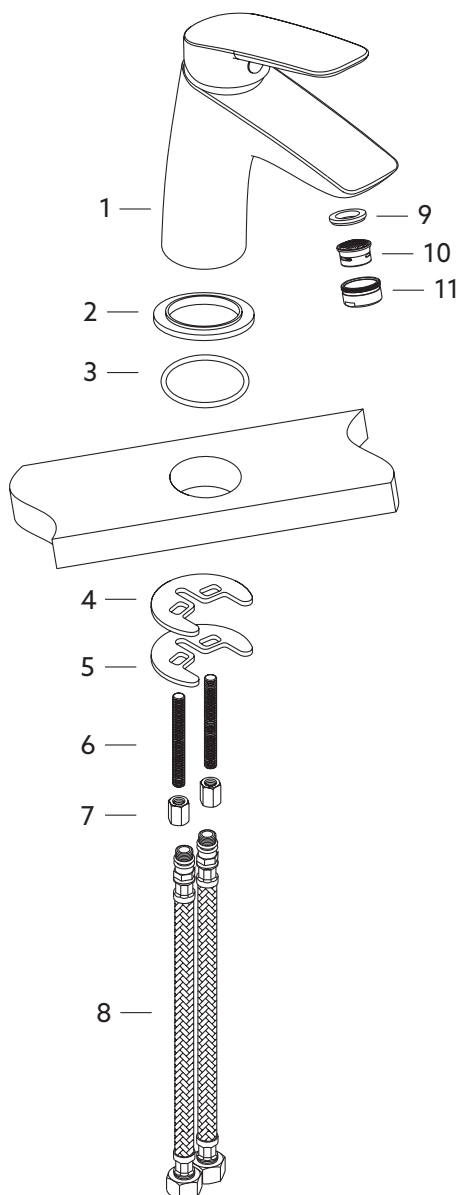

SPARE PARTS LIST:

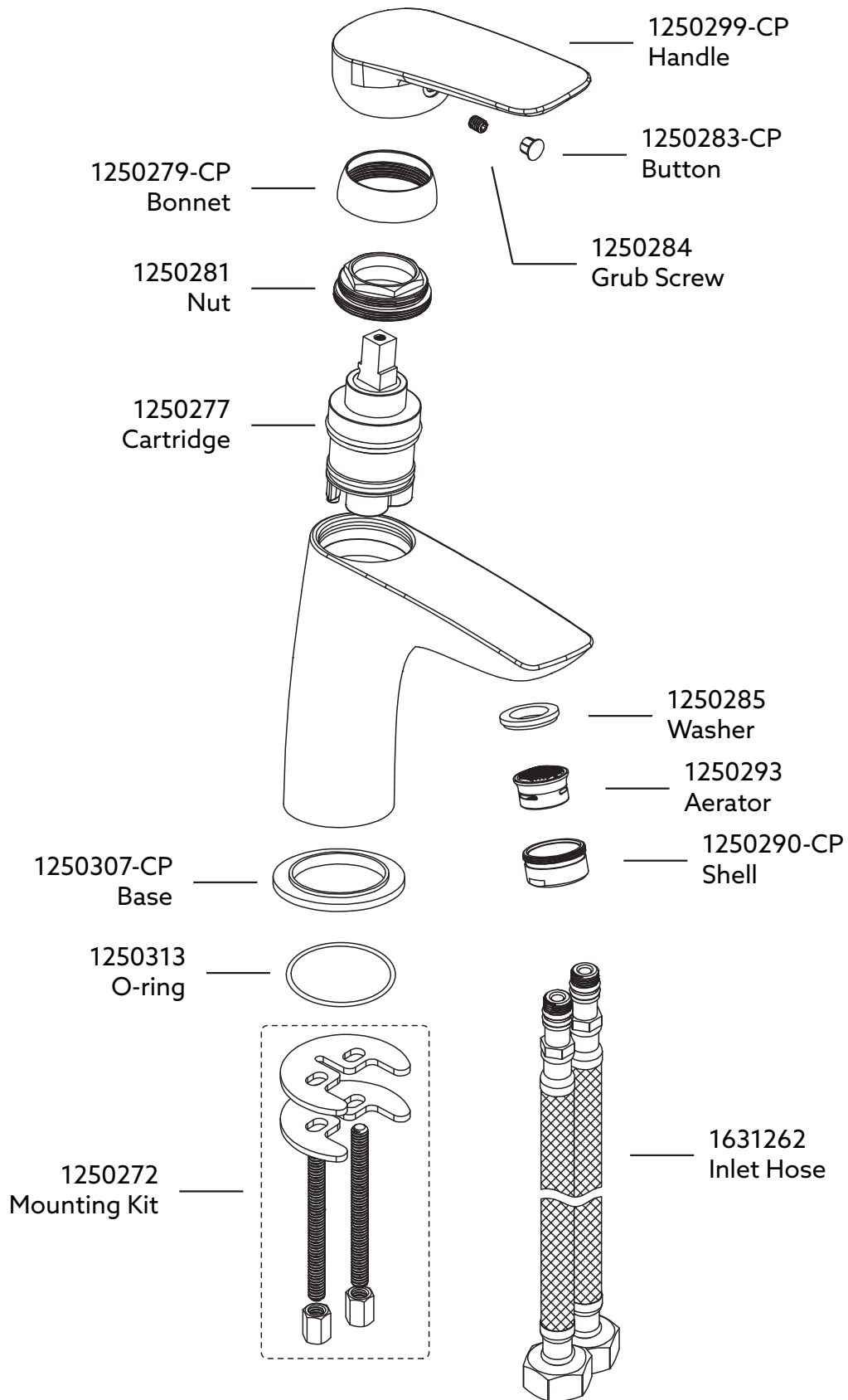

CLEANING INSTRUCTIONS:

All Finishes:

Clean the finish with mild soap and warm water. Wipe entire surface completely dry with a clean soft cloth. Many cleaners / chemicals such as ammonia, chlorine, toilet chemicals etc, which could adversely affect the finish and are not recommended for cleaning.

Do not use abrasive cleaners or solvents on Englefield tapware.

CONTACT AND WARRANTY INFORMATION:

NEW ZEALAND
KOHLER NZ LTD

0800 100 382
info@englefield.co.nz
englefield.co.nz

AUSTRALIA

englefield.com



For warranty information, please visit our website.