

BEFORE YOU BEGIN

Important: Installation of this Vario Connector must be done in accordance with AS/NZS3500.1.

The Kohler Vario Pan Connector can be adjusted to suit a range of S-trap toilet pan installations. For pans with a P-trap outlet, it converts the toilet pan from a P-trap to S-trap.

Depending on the pan geometry, this Vario Pan Connector is suitable for set-outs ranging from 70mm to ~ 210mm. The height is adjustable 80mm ~ 200 mm.

The ribbed cut lines for pan spigot depth adjustment is 195mm.

Ensure to maintain a minimum of 30mm overlap between the pan spigot and the Diaphragm Seal.



CAUTION: The trim cut(s) must be made square to the connector. Rotating the components during trimming can help keep the cut even.

INSTALLATION

1. Remove the locking ring and seal from the end of the Vario Connector.
2. Determine the waste pipe set-out (distance from waste pipe centre to the wall, (shown as dimension A in the diagram next page).

3. Mark and trim Screw Connector Bracket at the length of dimension A less 38mm (e.g: if measured 90mm, mark for cutting at 52mm).

4. Measure the distance from the pan spigot end to the wall (shown as dimension B in the diagram). Add 88mm and subtract dimension A. Mark connector at this length.

Formula for trimming: Length = B + 88 - A

(e.g: if A=90 and B=114,
Trim length = 114+88-90 = 112mm

5. Accurately trim the Spigot Connector to the marked length without damaging the rib-feature holding the seal in place. Tidy up the ends with a file, remove debris and replace the locking ring and seal.

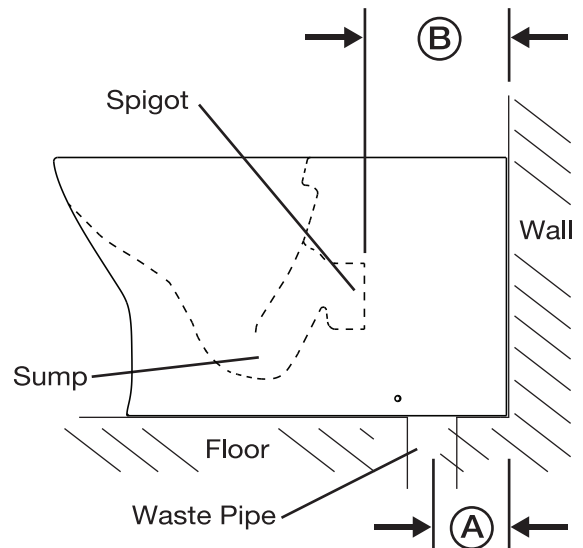

6.1. To use the Vario bend without offset pan collar, cut the waste pipe connector to adjust the length to suite the waste pipe.

6.2. To use the Vario bend with offset pan collar, insert waste pipe connector into offset pan collar. It may be necessary to trim the waste pipe connector to ensure it fully engages the offset pan collar.

7. Check the fit of connector + offset pan collar (if used) between pan, wall and waste pipe.

8. Cut the Screw Connector Bracket to length, slot it over the mount on the rear of the Spigot Connector and attach to the wall.

9. Lubricate Diaphragm Seal and carefully push the toilet pan back into the Vario Connector.

10. Proceed with pan installation as per the instructions supplied with the toilet.

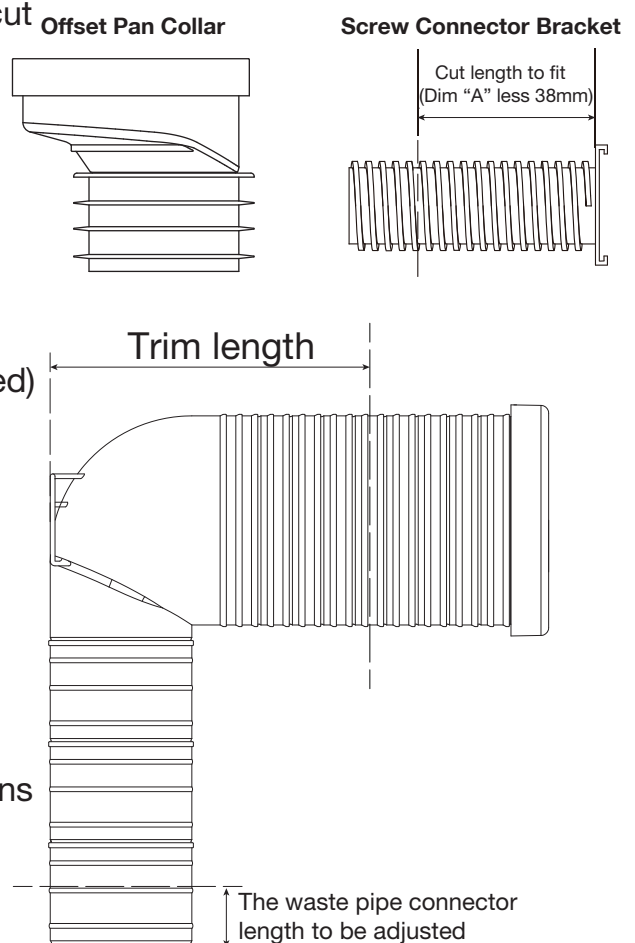

CONTACT AND WARRANTY INFORMATION

NEW ZEALAND
 KOHLER NZ LTD
 Free Ph: 0800 564 537
 (0800 KOHLER)
 Free Fax: 0800 664 488
 www.kohler.co.nz

AUSTRALIA
 KOHLER AUSTRALIA
 Free Ph: 1800 564 537
 (1800 KOHLER)

www.kohler.com.au